

Part No.:

B05-015NXNN6-XXA

Color: _____

1: black

2: Gray

Entry hole sizes: _____

65: OD 6.5mm

80: OD 8.0mm

1A: OD 10.0mm

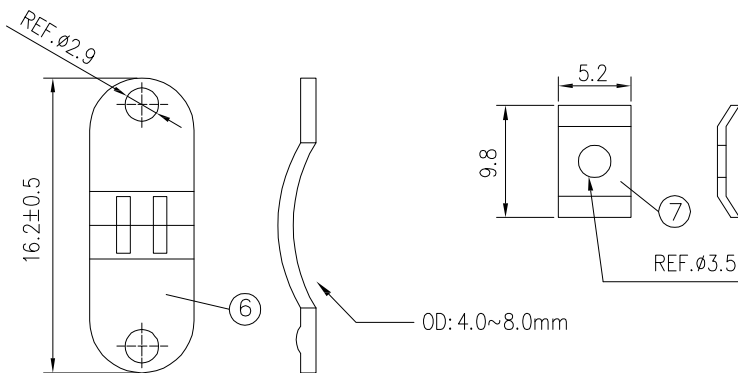
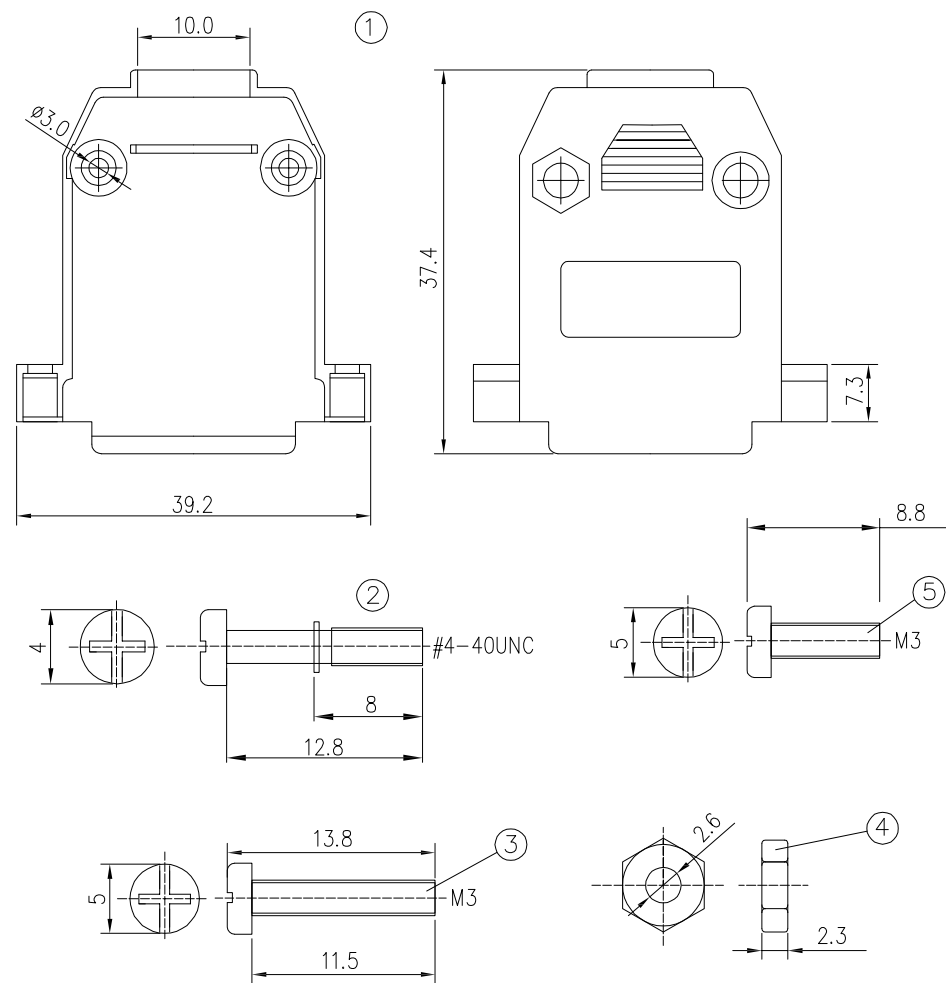

| 7 | Gaskets | SPCC | Plating: Ni | 2pcs |
|------|---------------|----------|---------------------|------|
| 6 | Cable clip | SPCC | Plating: Ni | 2pcs |
| 5 | Clip screw M3 | Steel | Plating: Ni | 2pcs |
| 4 | Nut M3 | Steel | Plating: Ni | 2pcs |
| 3 | Screw M3 | Steel | Plating: Ni | 2pcs |
| 2 | Screw 4#40 | Steel | Plating: Ni | 2pcs |
| 1 | Hood | ABS | Color: see part no. | 1set |
| Item | Desc. | Material | Remarks | Qty |

| △ | 2023/11/07 | Adjustment of new mould size | Jack Chen |
|------|------------|---|-----------|
| △ | 2019/02/18 | Increase the specification of screw threads | Jack Chen |
| △ | 2011/03/11 | First edition release | King Zhou |
| SIDE | DATE | DESCRIPTION | APPROVER |
| 8 | 7 | 6 | 5 |

| | |
|-----------------|-------|
| QUALITY SYMBOLS | |
| □ : | ☒ : |
| CRITICAL | MAJOR |
| ▽ : | ▽ : |
| ZERO DEFECT | S.P.C |

| Tolerance | |
|-----------|-------|
| .x | ±0.80 |
| .x | ±0.50 |
| .xx | ±0.25 |

| | | | | | | | |
|---|---------------------------------------|-------|------------|---|------------------|--------|-------------|
| NAME: | D-SUB 15pin plastic hood, short screw | | | PART NO. | B05-015NXNN6-XXA | | |
| REV: | C | UNIT: | mm | DRW BY | CHK BY | APP BY | DRAWING NO. |
| SCALE: | N:1 | DATE: | 2011/03/11 | Huangmei | Jack Chen | | B05-002 |
|  东莞市林诚塑胶电子有限公司 | | | | http://www.lineconn.com TEL:0769-85181660 85181770 | | | |